

J:\Brochure Drawings\06-253-3 Century\06-253-3-7.dwg, 9/7/2011 4:50:51 PM, Adobe PDF, 1:345

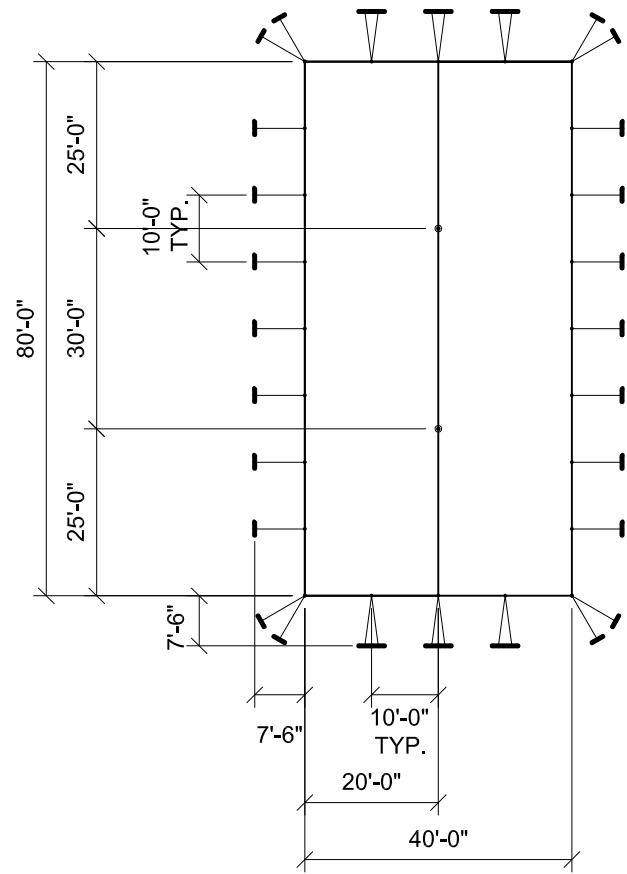

**PLAN**

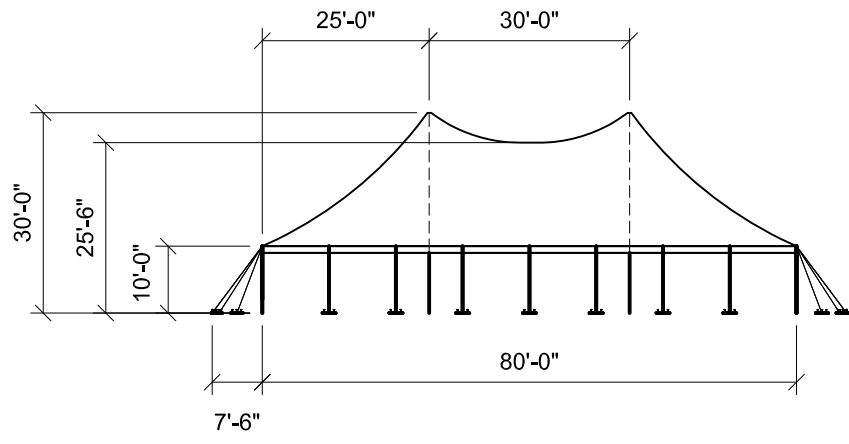

**END ELEVATION**

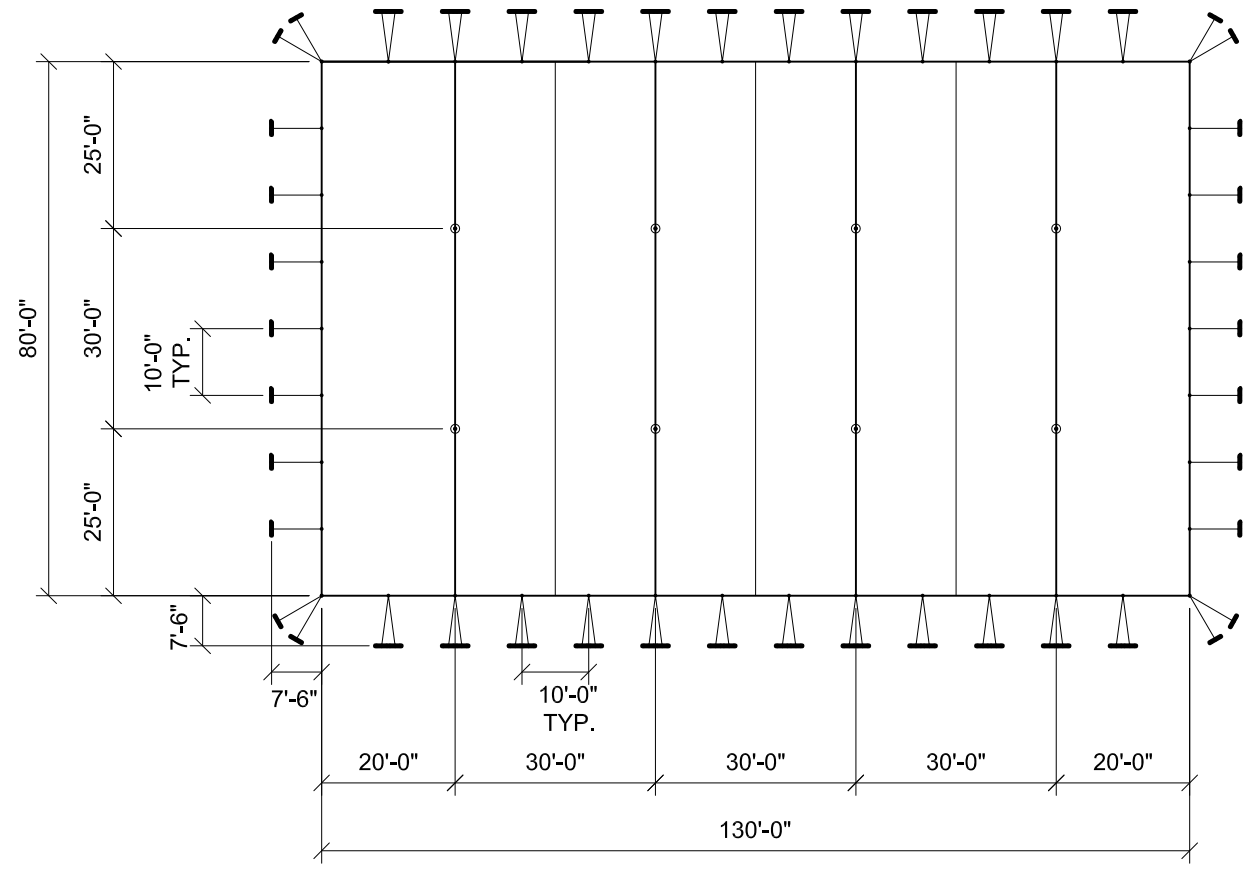

**PLAN**

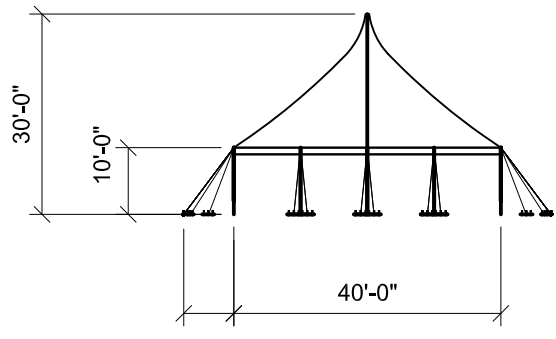

**SIDE ELEVATION**  
SCALE: 1" = 30'

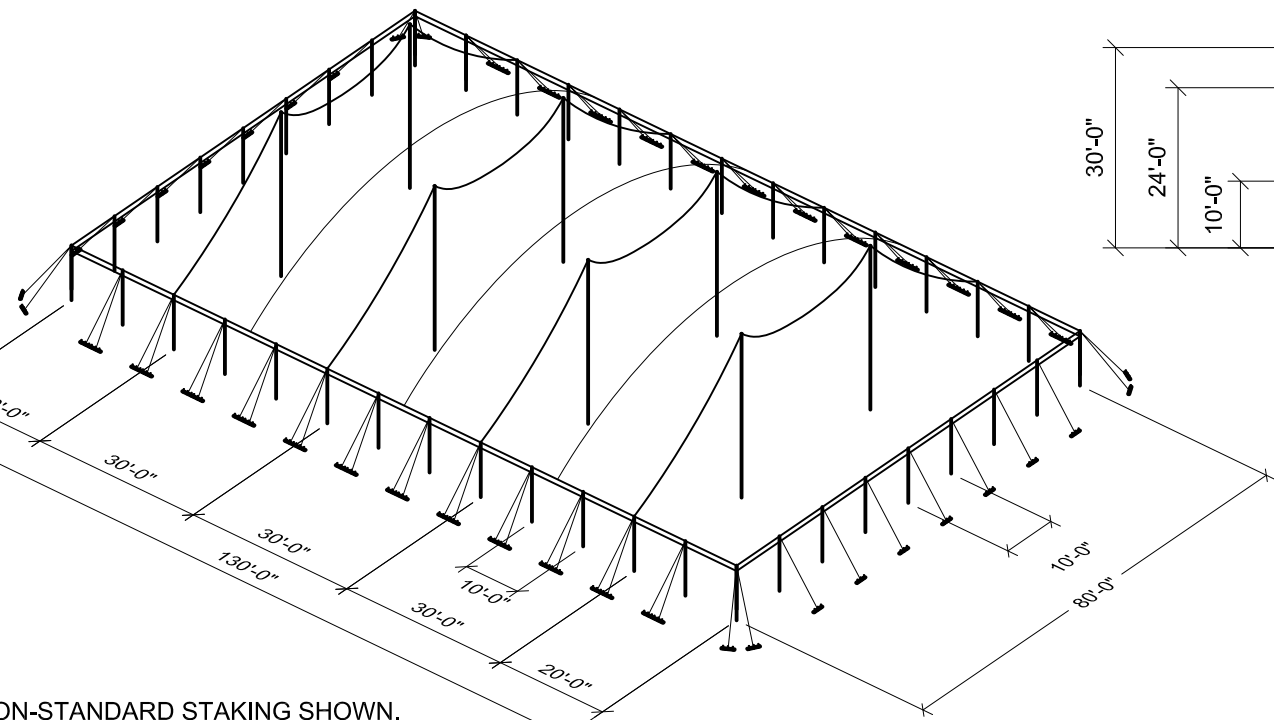

**ISOMETRIC**

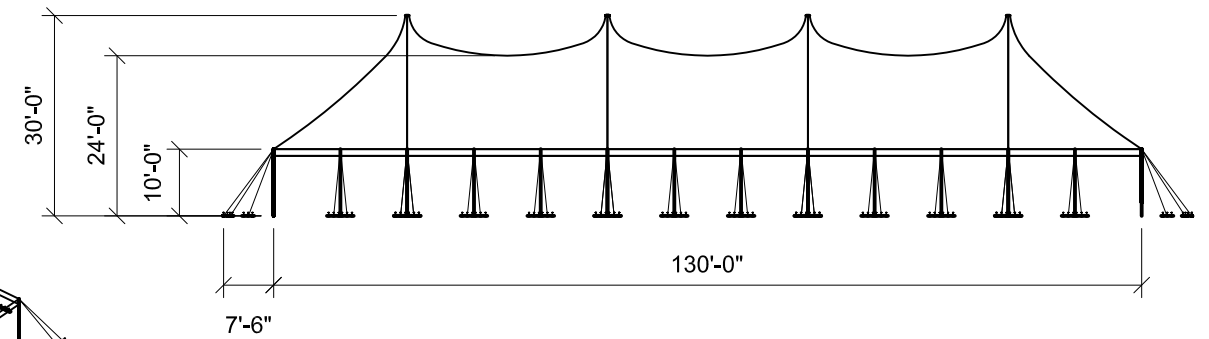

**SIDE ELEVATION**

NON-STANDARD STAKING.

**NOTES:**

1. GUY WEBS THROUGHOUT.
2. 10'-0" SIDE POLE SPACING.
3. 10'-0" EAVE HEIGHT SHOWN.
4. REF. B3-80M REV. 7-31-06.
5. NON-STANDARD STAKING SHOWN.
6. SEE THE I.F.A.I. STAKING GUIDE ON OUR WEBSITE (WWW.ANCHORINC.COM) FOR SOIL IDENTIFICATION & PULL-OUT CAPACITY OF STAKES.

REVISIONS		
EC/PR NO.	DATE	BY
1	05-10-11	DMK
2	09-07-11	DMK

<b>ANCHOR INDUSTRIES INC.</b>		
<b>BROCHURE DRAWING</b>		
<b>80' CENTURY TENT WITH 30' MIDS</b>		
DRAWN BY: DMK	CHECKED BY:	DRAWING NO.
APPROVED BY:	EC/PR NO.	DATE: 08-18-06
		<b>06-253-3-7</b>